

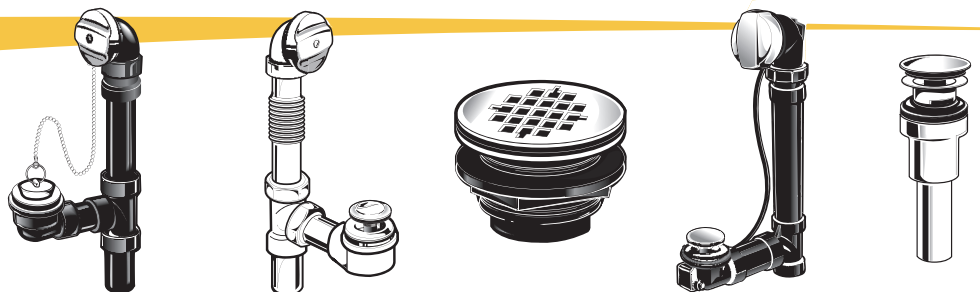

Evolution Through  
**INNOVATION**<sup>™</sup>





**Here it is! Sometime in the making, but we think you'll be as excited about our new catalogue as we are! We've made it even easier to use than ever before, and have added features such as a Company and Agent Contact List and Special Finishes Guide!**

**It's easy to use...**

1. Pick the Section using the colour coded Section Guide at the front of the catalogue.
2. Find the Product using the Table of Contents located at the beginning of each Section.
3. Choose the desired Product on the appropriate Catalogue Page.
4. Locate the Price in the alphanumeric Price List at the back of each Section.

**OUR NEW LOOK!**

**PRODUCT PAGE**

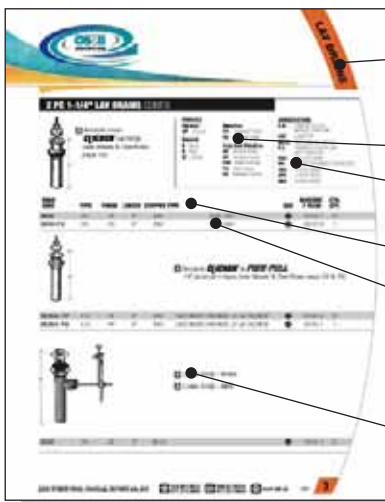

- **SECTION TABS** Each Section is identified by colour coded tabs. The coloured tabs are used throughout each Section.
- **FINISHES** Guide found at the top of each page for quick reference.
- **ABBREVIATIONS** Guide defines the abbreviations that are used within that particular Section.
- **CATEGORY** Headers help quickly identify the major product categories within each Section.
- **INFORMATION** – Columns: We've broken down the product descriptions into easy to follow Columns to make it easier to quickly identify the product you need.
- **FEATURE** Bullets highlight the special features or characteristics for that particular product.

**PRICE PAGE**

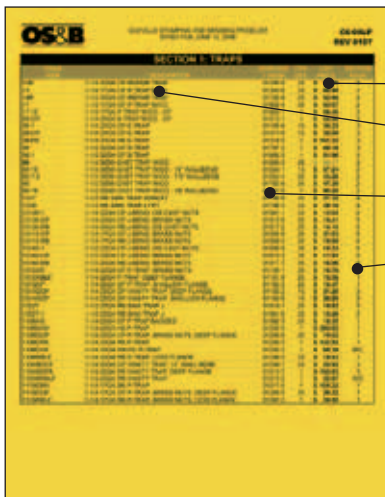

- **Product Pricing** is now found at the back of each section in the coloured Alphanumeric Price List.
- The Price List shows a brief product **description**.
- **UPC Codes** are now indicated, as are case quantities.
- The corresponding catalogue **Section page** is also indicated for quick cross reference.



Dear Valued Customer,

Please be advised that effective February 2, 2007, the **List price** on a small number of items has been increased or decreased as a result of fluctuations in the cost of raw materials. The affected items, listed below, are bolded on the enclosed PRICELIST in their appropriate section, for ease of identification.

<b>OS&amp;B ITEM</b>	<b>CATALOGUE SECTION</b>	<b>OLD LIST</b>	<b>NEW LIST</b>
<b>110BDPC</b>	TRAPS	\$19.62	\$21.28
<b>309CS-BN</b>	WASTE & OVERFLOW	\$402.12	\$354.76
<b>BOT-CP</b>	TRAPS	\$235.38	\$86.00
<b>BOT-BN</b>	TRAPS	\$319.60	\$151.00
<b>VINPAK-1</b>	TUB & SHOWER	\$14.63	\$15.87
<b>VINPAK-7</b>	TUB & SHOWER	\$30.72	\$33.33
<b>SD35</b>	TUB & SHOWER	\$9.80	\$8.48
<b>SD45</b>	TUB & SHOWER	\$20.42	\$17.46
<b>2114-35</b>	TUB & SHOWER	\$1.43	\$1.78
<b>2114</b>	TUB & SHOWER	\$0.77	\$0.96
<b>2113</b>	TUB & SHOWER	\$1.31	\$1.79
<b>2113-35</b>	TUB & SHOWER	\$1.68	\$1.98
<b>2115</b>	TUB & SHOWER	\$2.33	\$3.56
<b>110DCP</b>	TRAPS	\$18.18	\$19.73
<b>V-200</b>	ETC.	\$3.02	\$3.21
<b>3600</b>	LAV DRAINS	\$18.69	\$20.26
<b>SPUD-22</b>	TUB & SHOWER - W/C	\$11.33	\$13.03
<b>SPUD-11</b>	TUB & SHOWER - W/C	\$7.41	\$8.52
<b>110BAG</b>	TRAPS	\$18.35	\$20.48

We are excited to announce some new items and categories, including **Drain Pans** (Section 8) and a complete line of **Kitchen, Bar & Commercial Strainers** (Section 9).

Without a doubt though, our biggest news is the introduction of a **Waste & Overflow Rough-In & Trim Kit program**. The **RI&T** program allows you to stock ABS Clicker™ and Cable-Drive® Rough-In and Trim Kits separately in today's most popular finishes, maximizing your options while minimizing your SKU count. Turn to the first two pages of the Waste & Overflow Section in your new catalogue for the complete details...

Please note that availability will vary on these new products during the 1st quarter of the year. Please call us to check availability.

Finally, you spoke, and we listened! You asked for toll free telephone and fax numbers, and now we have them:

<b>Telephone:</b>	<b>Local:</b>	<b>905.827.0320</b>
	<b>Toll Free:</b>	<b>877.314.6040</b>
<b>Fax:</b>	<b>Local:</b>	<b>905.827.6375</b>
	<b>Toll Free:</b>	<b>877.827.6040</b>

Thank-you for your support in 2006, and wishing you much success in 2007!

Team **OS&B**

## AGENT

## BRITISH COLUMBIA

**Canadian Aqualine Sales Inc.**  
 Elaine Woof  
 Richard Lacey  
 Mark Wilson  
 #160-7391 Vantage Way  
 Delta, BC  
 V4G 1M3  
 T. 604.946.4811  
 F. 604.946.4825  
 Email: mark@can-aqua.com  
 Website: www.can-aqua.com

## ALBERTA

**Canadian Aqualine Sales Inc.**  
 Bruce Stringer  
 Mike Stringer  
 Morgan Chollack  
 #115 – 11198-42<sup>nd</sup> Street S.E.  
 Calgary, AB  
 T2C 0J9  
 T. 403.243.3387  
 F. 403.243.5011  
 Email: mike@can-aqua.com  
 Website: www.can-aqua.com

## SASKATCHEWAN

**RAM Mechanical Marketing**  
 Glenn Camrud  
 510 Avenue M. South  
 Saskatoon, SK  
 S7M 2K9  
 T. 306.244.6622  
 F. 306.244.0807  
 Email gcamrud@shaw.ca

## MANITOBA &amp; LAKEHEAD ON

**Mar-Win Agencies Ltd.**  
 Todd Witzleben  
 1333 Clifton St.  
 Winnipeg, MB  
 R3E 2V1  
 T. 204.775.8194  
 F. 204.786.8016  
 Email: marwin@mts.net

## ONTARIO - SOUTHWESTERN

**Palser Enterprises Ltd.**  
 Stu Liddell  
 Address: 1885 Blue Heron Drive,  
 Unit #10  
 P.O. Box 28136  
 London, ON  
 N6H 5R2  
 519.471.9382  
 T. 519.471.9382  
 F. 519.471.1049  
 Email: sales@palserent.com

## ONTARIO – GTA

**Oakville Stamping & Bending Ltd.**  
 2200 Speers Road  
 Oakville, ON  
 L6L 2X8  
 T. 905.827.0320  
 F. 905.827.6375  
 Email: osb@osb.ca  
 Website: www.osb.ca

## ONTARIO – EASTERN

**Can-Mech Agencies Ltd.**  
 Doug Parsons  
 151 Tansley Drive  
 Carp, ON  
 K0A 1L0  
 T. 613.831.3724  
 F. 613.831.3727  
 Email: dparsons@canmech.com

## QUEBEC

**Can-Aqua International Ltée.**  
 Jean Beaudoin  
 1955 Boulevard Dagenais Ouest  
 Laval, QC  
 H7L 5V1  
 T. 450.625.3088  
 F. 450.625.3365  
 Email: info@can-aqua.ca

## NEW-BRUNSWICK/PEI

**Eastwin Enterprises Ltd.**  
 Darren Ross  
 136 Highmeadow Drive  
 Moncton, NB  
 E1G 2C3  
 T. 506.863.9862  
 F. 902.463.2626  
 Email: Eastwin@nbnet.nb.ca

## NOVA SCOTIA

**Eastwin Enterprises Ltd.**  
 Jim Barkhouse  
 Box 2998 D.E.P.S.  
 Dartmouth, NS  
 B2W 4Y3  
 T. 902.462.8440  
 F. 902.462.8445  
 Email: jimbarkhouse@ns.aliantzinc.ca

## NEWFOUNDLAND &amp; LABRADOR

**J.D.S. Sales Ltd.**  
 Jim Sweetapple  
 4 Lancaster Street  
 St. John's, Nfld.  
 A1A 5P7  
 T. 709.579.5771  
 F. 709.579.1558  
 Email: jds@nf.sympatico.ca

## COMPANY

**Oakville Stamping & Bending Ltd.**  
 2200 Speers Road  
 Oakville, ON  
 L6L 2X8  
 T. 877.314.6040  
 F. 877.827.6040  
 Email: osb@osb.ca  
 Website: www.osb.ca

## Technical enquiries:

Craig Smith, Product Specialist  
 Ext. 102  
 Email: tech@osb.ca

## Sales enquiries:

Michael Pinet, Director of Sales and Marketing  
 Ext. 104  
 Email: sales@osb.ca

Cathy Morley, Manager - Boutique Sales  
 Ext. 101  
 Email: boutiquesales@osb.ca

## Order/Price &amp; Availability/Shipment enquiries:







Judi Meade, Customer Service  
 Ext. 113  
 Email: customerservice@osb.ca

## Management:

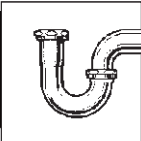
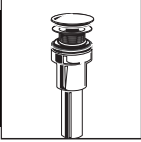
Brent Cornelissen, General Manager  
 Ext. 112  
 Email: osb@osb.ca

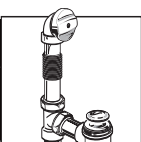
Kevin Ernst, VP of Operations  
 Ext. 114  
 Email: osb@osb.ca

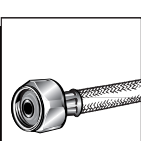
# Table of Contents - Sections

	Traps	<b>1</b>
	Lav Drains	<b>2</b>
	Tubular Brass	<b>3</b>
	Tubular Plastic	<b>4</b>
	Waste & Overflow	<b>5</b>
	Tub & Shower - W/C	<b>6</b>
	Supplies	<b>7</b>
	Etc.	<b>8</b>
	Strainers	<b>9</b>
OS&B Green		<b>10</b>



**SECTION 4 • TUBULAR PLASTIC** — Table of Contents

TYPE	SIZE	PAGE(S)
<b>TUBULAR TRAPS</b>		
	1-1/2"	1
<b>CONTINUOUS WASTES</b>		
	1-1/2"	1 & 2
<b>EXTENSION TUBES - SOLVENT CEMENT</b>		
	1-1/2"	3
<b>EXTENSION TUBES - SLIP JOINT</b>		
	1-1/2"	3
<b>SINK TAILPIECES</b>		
	1-1/2"	3
<b>DISHWASHER TAILPIECES</b>		
	1-1/2"	4
<b>REPAIR CONNECTORS - PLASTIC</b>		
	1-1/2"	5
<b>DISHWASHER BUSHINGS</b>		
	1-1/2"	5



**1-1/2" TUBULAR TRAPS**

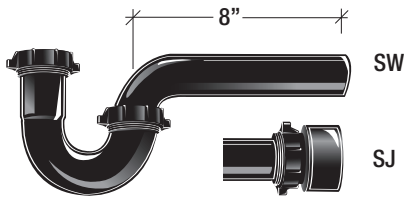

**ABBREVIATIONS**

- CO** CENTRE OUTLET
- DC** DIRECT CONNECT
- EO** END OUTLET
- FIPT** FEMALE IRON PIPE THREAD
- MIPT** MALE IRON PIPE THREAD
- SJ** SLIP JOINT
- TLPC** TAILPIECE

OS&B CODE	SIZE	LENGTH	CSA	BARCODE 7 75439-	CTN. QTY.
614	1-1/2"	1-1/4" & 1-1/2" INLET, SOLVENT WELD	CSA	04104 6	25
614-SJ	1-1/2"	1-1/4" & 1-1/2" INLET, SJ ADAPTER		04101 5	25

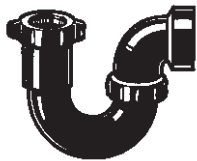

6227	1-1/2"	1-1/4" & 1-1/2" INLET, SOVENT WELD HUB		04103 9	25
61227	1-1/2"	1-1/4" X 1-1/2" INLET, FEMALE (FIPT) OUTLET		04100 8	25

**1-1/2" CONTINUOUS WASTES**

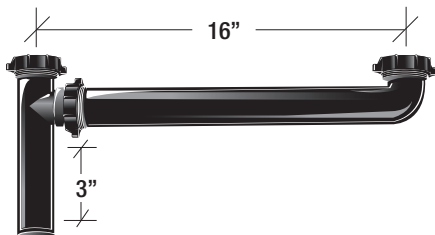

6265-DC	1-1/2"	16"		04200 5	25
6265-SJ	1-1/2"	16"		04201 2	25



**1-1/2" CONTINUOUS WASTES CONT'D**

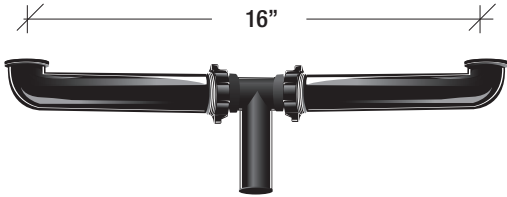

**ABBREVIATIONS**

- CO** CENTRE OUTLET
- DC** DIRECT CONNECT
- EO** END OUTLET
- FIPT** FEMALE IRON PIPE THREAD
- MIPT** MALE IRON PIPE THREAD
- SJ** SLIP JOINT
- TLPC** TAILPIECE

<b>OS&amp;B CODE</b>	<b>SIZE</b>	<b>LENGTH</b>		<b>CSA</b>	<b>BARCODE 7 75439-</b>	<b>CTN. QTY.</b>
6267-DC	1-1/2"	16"	CENTRE OUTLET, DIRECT CONNECT		04202 9	25
6267-SJ	1-1/2"	16"	CENTRE OUTLET, SLIP JOINT		04203 6	25



**1-1/2" EXTENSION TUBES - SOLVENT CEMENT**



**ABBREVIATIONS**

- CO** CENTRE OUTLET
- DC** DIRECT CONNECT
- EO** END OUTLET
- FIPT** FEMALE IRON PIPE THREAD
- MIPT** MALE IRON PIPE THREAD
- SJ** SLIP JOINT
- TLPC** TAILPIECE

OS&B CODE	SIZE	LENGTH	CSA	BARCODE 7 75439-	CTN. QTY.
6804-6	1-1/2"	6"		04302 6	25
6804-8	1-1/2"	8"		04304 0	12
6804-12	1-1/2"	12"		04300 2	12
6804-16	1-1/2"	16"	HUB BOTH ENDS	04301 9	1

**1-1/2" EXTENSION TUBES - SLIP JOINT**



Includes nut & packing ring

6809-6	1-1/2"	6"		04314 9	25
6809-8	1-1/2"	8"		04313 2	1
6809-12	1-1/2"	12"		04310 1	12
6809-16	1-1/2"	16"	SJ BOTH ENDS	04311 8	25

**1-1/2" SINK TAILPIECES**



Supplied less nut & washer

6812-1	1-1/2"	1"		04320 0	1
6812-4	1-1/2"	4"		04323 1	25
6812-6	1-1/2"	6"		04324 8	25
6812-8	1-1/2"	8"		04325 5	25
6812-12	1-1/2"	12"		04321 7	12
6812-16	1-1/2"	16"	FLANGED BOTH ENDS	04322 4	12

## 1-1/2" DISHWASHER TAILPIECES

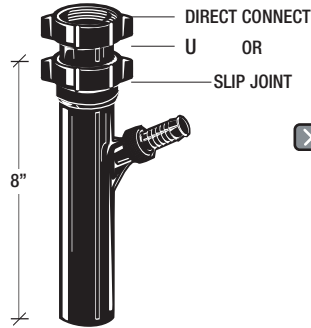

➤ Branch: Hose thread or clamp

### ABBREVIATIONS

- CO** CENTRE OUTLET
- DC** DIRECT CONNECT
- EO** END OUTLET
- FIPT** FEMALE IRON PIPE THREAD
- MIPT** MALE IRON PIPE THREAD
- SJ** SLIP JOINT
- TLPC** TAILPIECE

OS&B CODE	SIZE	LENGTH		CSA	BARCODE 7 75439-	CTN. QTY.
6868-U	1-1/2"	8"	UNIVERSAL, COMPLETE WITH WASHERS		04402 3	25

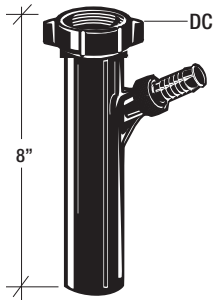

➤ Branch: Hose thread or clamp

6868-DC	1-1/2"	8"	DIRECT CONNECT, COMPLETE WITH WASHERS	CSA	04400 9	25
---------	--------	----	---------------------------------------	-----	---------	----

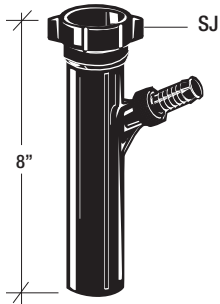

➤ Branch: Hose thread or clamp

6868-SJ	1-1/2"	8"	SLIP JOINT, COMPLETE WITH PACKING RING	CSA	04401 6	25
---------	--------	----	--	-----	---------	----



**1-1/2" REPAIR CONNECTORS - PLASTIC**



**ABBREVIATIONS**

- CO** CENTRE OUTLET
- DC** DIRECT CONNECT
- EO** END OUTLET
- FIPT** FEMALE IRON PIPE THREAD
- MIPT** MALE IRON PIPE THREAD
- SJ** SLIP JOINT
- TLPC** TAILPIECE

OS&B CODE	SIZE			CSA	BARCODE 7 75439-	CTN. QTY.
6866	1-1/2"	90° ELBOW, SJ x SJ	COMPLETE W/NUTS & PACKING RINGS		04121 3	25

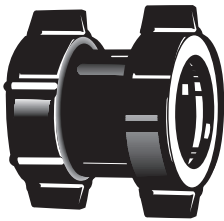

6862	1-1/2"	SJ x SJ	COMPLETE W/NUTS & PACKING RINGS		04120 6	25
------	--------	---------	---------------------------------	--	---------	----

**1-1/2" DISHWASHER BUSHINGS**

REMOVABLE END CAP

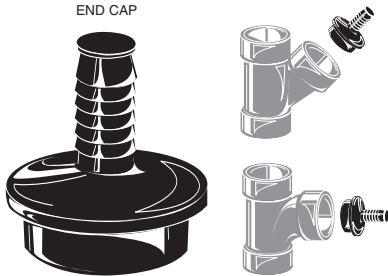

6300	1-1/2"	ABS/DWV - SCHEDULE 40 BARCODED		CSA	04403 0	50
------	--------	--------------------------------	--	-----	---------	----



Evolution Through  
**INNOVATION**<sup>TM</sup>

Manufacturer of Quality  
Brass and Tubular Products



2200 Speers Road, Oakville, Ontario L6L 2X8

• 1.877.314.6040 •

[www.osb.ca](http://www.osb.ca)